

# PERIPHERAL AND CENTRAL AUDITORY ASSESSMENT



Ravi Pachigolla, MD

Jeffery T. Vrabec, MD

# Introduction



- Pure tone audiometry
- Tympanometry
- Acoustic reflex measurements
- ECochG
- Auditory Brainstem Response (ABR)
- Otoacoustic Emissions

# Pure Tone Audiometry

- Most common test
- Threshold of audibility
- Activation of auditory system
- Energy formatted into neural code
- Air conduction assesses entire system
- Bone conduction assesses cochlea onwards

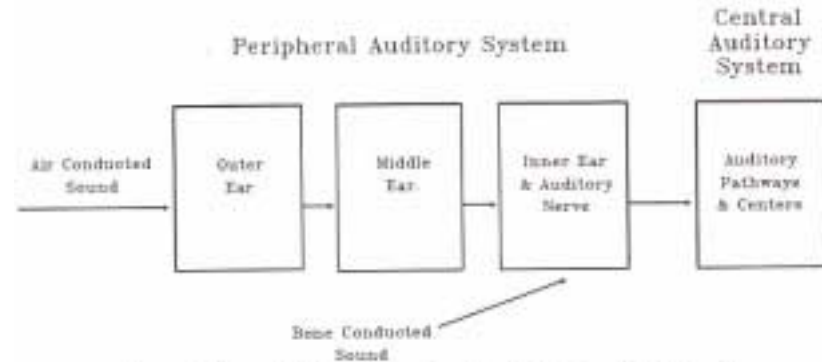

Figure 1. Schematicized pathways for air- and bone-conducted sound.

# Pure Tones



- Auditory acuity
- Spectrally specific
- High frequency tones stimulate basal turn of the cochlea
- Low frequency tones stimulate apical turn of the cochlea

# Decibel Scales

- Sound Pressure Level (SPL)
- Hearing Level (HL)
- Sensation Level (SL)

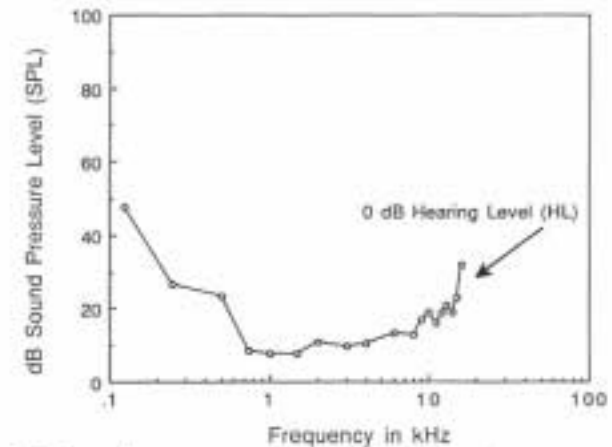

Figure 7. Human hearing sensitivity measured in dB sound pressure level (SPL) for frequencies from 125 Hz to 16 kHz. Thresholds from 125 Hz to 5 kHz are the ANSI 1969 standard for pure tone thresholds (ANSI, 1969) in a 6 cc coupler. Thresholds from 9 to 16 kHz are from Stelmachowicz PG et al, who used a combination of a real-ear probe and a custom-made coupler. (High-frequency data from Stelmachowicz PG, Gorga MP, Cullen JK: A calibration procedure for the assessment of thresholds above 5000 Hz. J Speech Hear Res 25:618-623, 1982.)

# Assessment of thresholds



- Octave frequencies tested
- Bone conduction thresholds
- Mastoid or forehead used
- Mastoid preferred because less intensity required
- Occlusion effect
- Ascending series of tone presentations

# Speech Audiometry



- Speech Reception Threshold using spondaic words
- Standardized word lists
- Familiarization with spondees
- Ascending series of presentation
- Excellent speech discrimination in conductive hearing loss patients
- Poor speech discrimination in cochlear hearing loss patients
- Poorest speech discrimination in retrocochlear hearing loss patients

# Clinical Masking



- Nontest ear can influence thresholds of test ear
- Shadow curve apparent without masking
- Interaural attenuation varies from 40 to 80 dB with air conduction
- Interaural attenuation is about 0 dB with bone conduction

# Shadow Curve

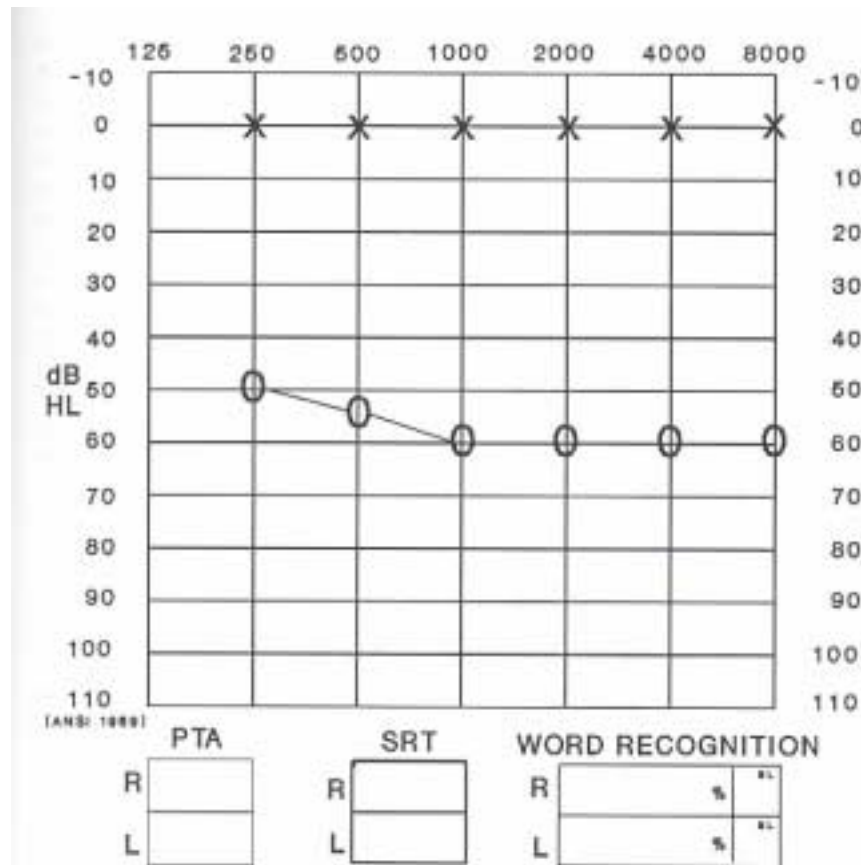

Figure 2. Pure tone audiometric example of air-conduction shadow curve for right ear caused by crossover hearing of test tone in left ear.

# Clinical Masking cont.



- Compare bone conduction threshold of nontest ear with air conduction threshold of test ear to determine whether masking is necessary

# Masking using narrow bands of noise

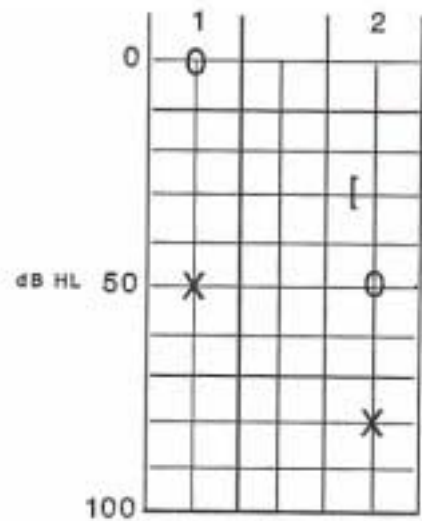

Figure 3. Two examples illustrating crossover hearing of test tone in nontest ear. In both examples, the dB difference between the response level at the test ear and the bone-conduction threshold of the nontest ear equal known values for interaural attenuation values for pure tones.

# Plateau method

- Mask nontest ear with progressively greater amounts of sound until threshold does not rise.
- Masking Dilemma

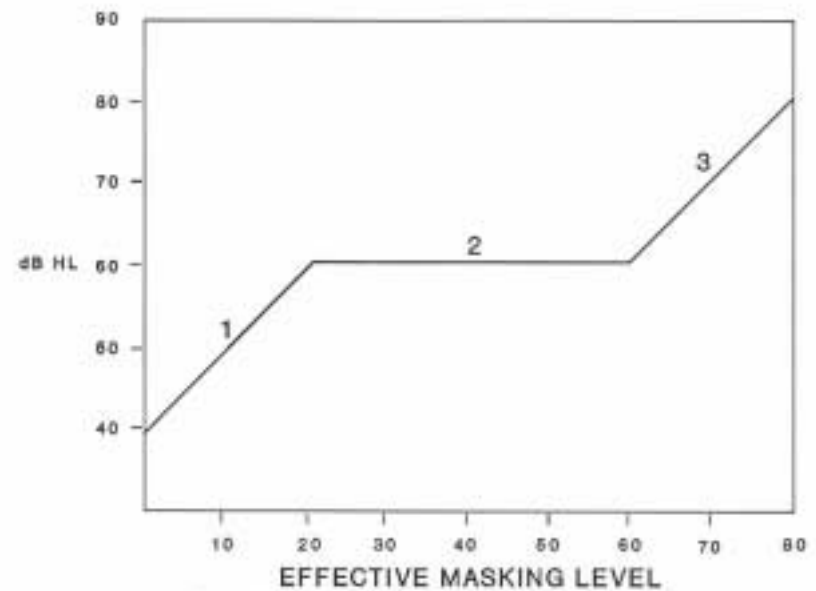

Figure 5. Function illustrating the masking plateau.

# Acoustic Immitance



- Impedance
- Reflected energy
- Tympanometry
- Acoustic Reflex

# Tympanometry configurations

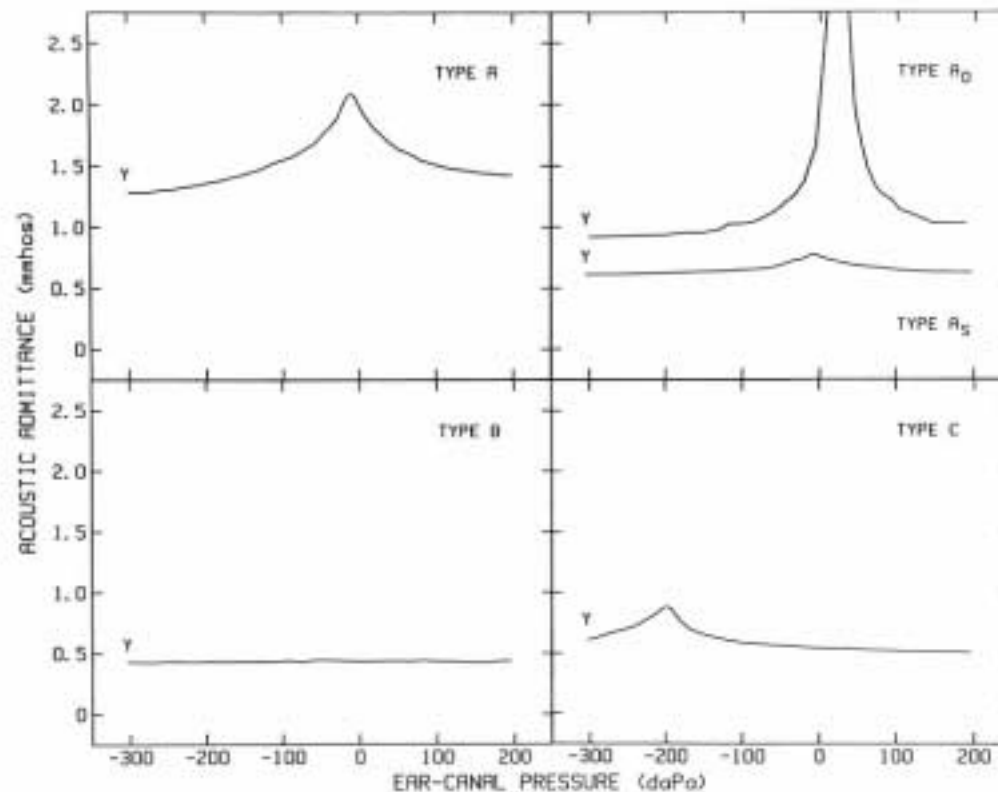

Figure 6. Five basic types of 226-Hz admittance tympanograms described by Liden<sup>18</sup> and Jerger.<sup>19</sup>

# Acoustic Reflex Threshold

- Stapedial muscle contraction
- Temporary increase in middle impedance
- Bilateral Stimulation
- Adaptation
- Neural network in lower brainstem

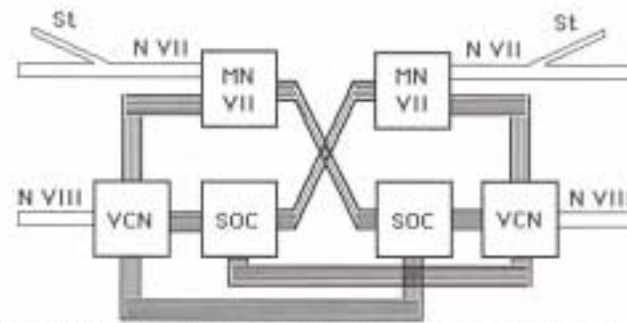

Figure 1. Acoustic-stapedius reflex (ASR) pathways. The afferent input to the ASR arc is the eighth cranial (auditory) nerve (N VIII). The central projections of N VIII synapse with dendrites in the ventral cochlear nucleus (VCN). The VCN sends projections to the ipsilateral and contralateral superior olivary complex (SOC) and to a region near the ipsilateral medial nucleus of the seventh cranial (facial) nerve (MN VII). The motoneurons of the stapedius muscle originate near MN VII and project via N VII to the stapedial nerve (St), which innervates the stapedius muscle in its bony canal in the posterior wall of the middle ear.

# Clinical application of ASR



- Middle Ear Disease
- Otosclerosis
- Cochlear hearing loss and loudness recruitment
- Retrocochlear lesions may abolish the ASR
- Brainstem lesions may abolish the contralateral reflexes
- Determination of site of a seventh nerve lesion
- Acoustic Reflex Decay

# Electrocochleography



- Cochlear Microphonic
- Summating Potential
- Compound Action Potential
- Increased SP/AP ratio suggests hydrops
- Ability to enhance wave I of the ABR in patients with severe high frequency hearing loss

# Electrocochleography setup

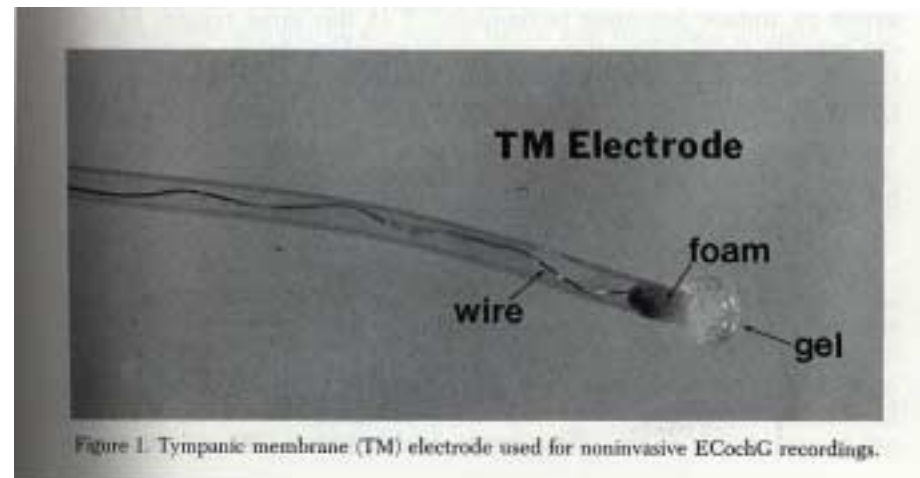

# ECochG and Meniere's

- Increased SP/AP ratio
- Latency not important
- Ratio greater than 0.45 suggests meniere's
- Hydrops affects elasticity of the basilar membrane

6 AUDITORY SYSTEMS

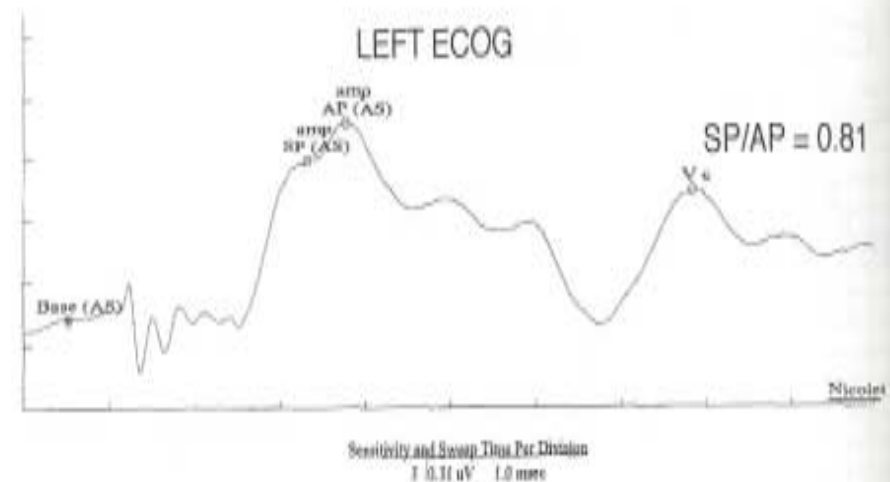

Fig. 146-9. Electrocochleogram obtained from the ear of a patient with Ménière's disease; the summing potential to action potential ratio is elevated (0.81).

# Auditory Brainstem Response



- Auditory evoked potential
- Farfield recording
- Acoustic clicks or tonal stimuli used
- Rate of stimulus presentation

# ABR continued

- Waves I - V
- Unaffected by sleep and pharmacotherapy
- ABR latencies decrease from birth until 2 years
- Wave V used for threshold testing (most robust)
- ABR thresholds about 10 to 20 dB poorer than behavioral measures

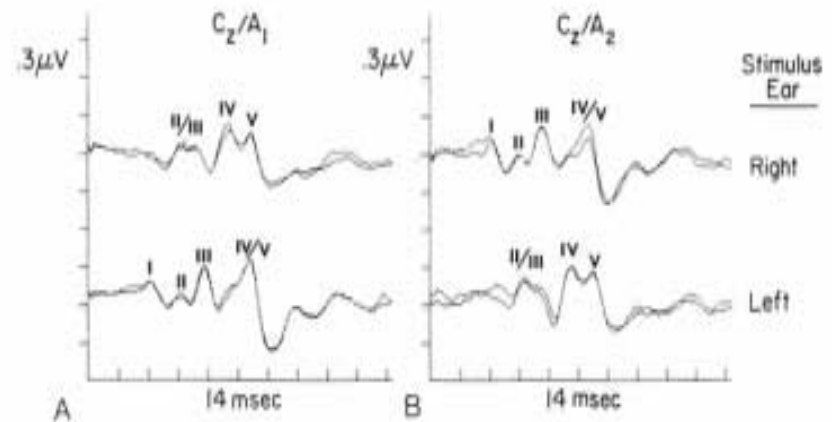

Figure 4. Normal click-evoked auditory brainstem response (ABR). A, The recordings were derived from the vertex (Cz) to left earlobe (A1) electrode montage and B, from the vertex to right earlobe (A2) electrode array. Stimulus ear is indicated to the right of the tracings. Roman numerals I through V = component waves.

# Latency of response

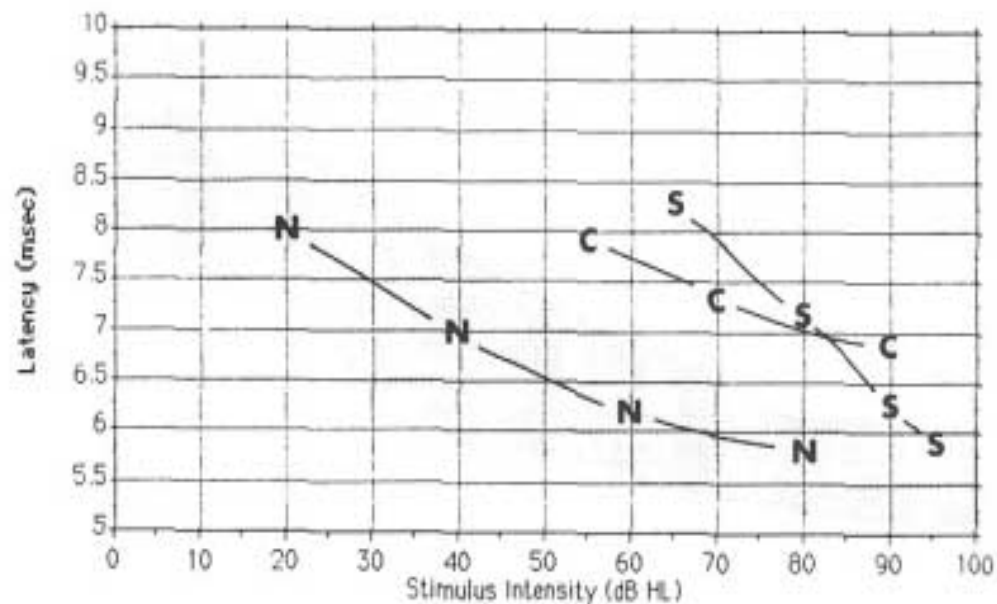

Figure 5. ABR wave V latency-intensity graph. Stippled area indicates normal values (mean  $\pm$  2.5 S.D.). N = plot of wave V latency as a function stimulus level for a normal hearing subject. C = plot of wave V latency as a function of stimulus level for patient with conductive hearing loss. S = plot of wave V latency as a function of stimulus level for patient with sensorineural (cochlear) hearing loss.

# ABR continued



- Lesions of the eighth cranial nerve
- Interwave latency
- Interaural latency difference
- Absolute latency
- Amplitude ratio

# Retrocochlear lesion

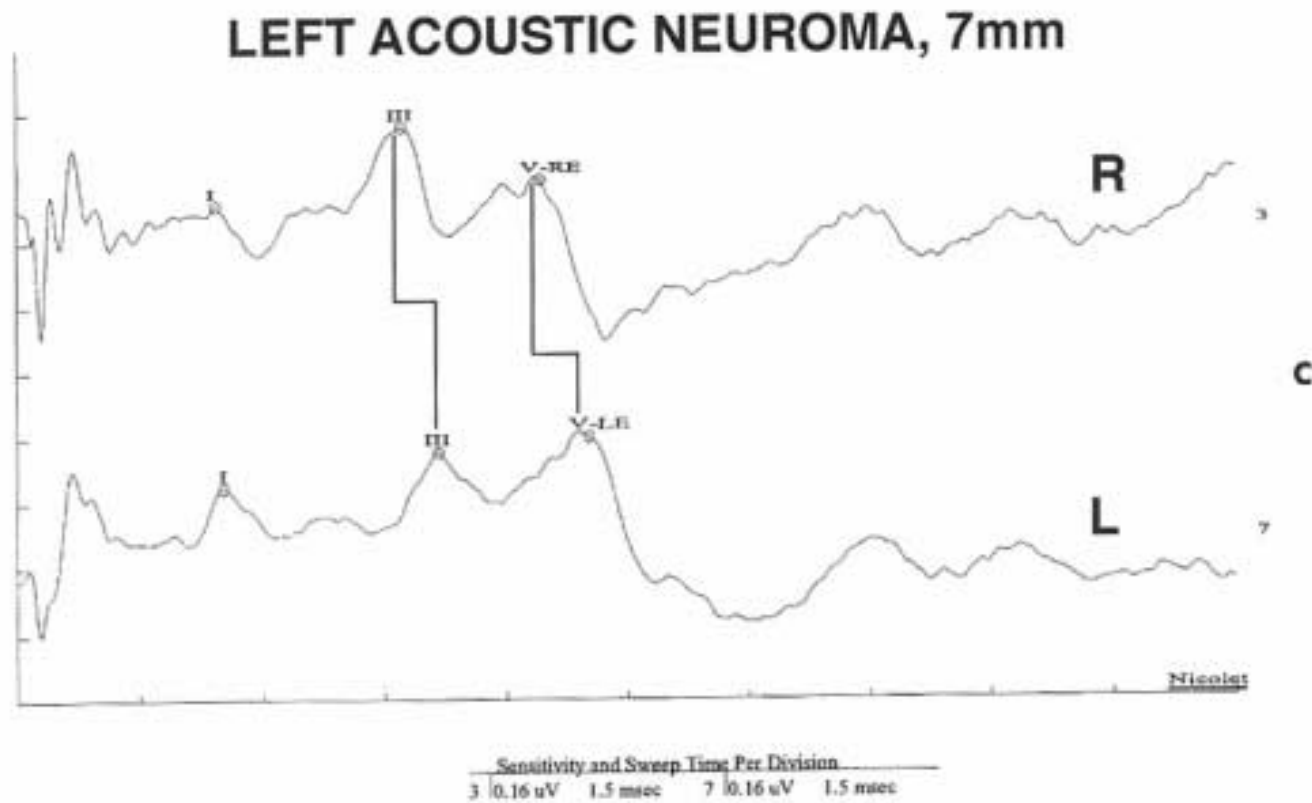

# Otoacoustic Emissions



- Energy leakage
- Evidence of a healthy, functioning cochlea
- Spontaneous and evoked emissions
- Evoked emission seen only in cochleae with thresholds less than 20 to 30 dB
- Conductive losses affect emissions
- Screening tool in infants

# Central Auditory Function



- Comprehension
- Background noise
- Behavioral tests
- Monotic vs. dichotic
- Monaural vs. binaural

# Case Presentation



- 31 yo male with left sided hearing loss noticed when listening to portable radio
- No other otologic complaints, no pmh or contributory family or social history
- PE normal

# Audiogram

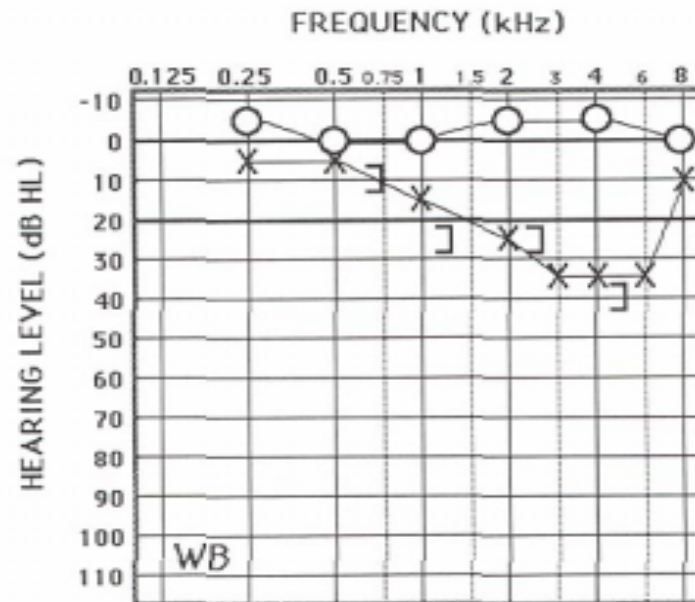

FREQ. (Hz)	ACOUSTIC REFLEXES			WORD RECOGNITION		
	1000	2000	4000	1000	2000	4000
CONTRA.	100	95	90	85	75	75
IPSI.	80	85	85	80	90	80
DECAY (ipsilateral)	NEG			?		

RIGHT		LEFT	
HL	%	HL	%
40 M	100%	40 M	100%
90 M	100%	90 M	88%

# Assessment



- Mild high frequency sensorineural hearing loss
- Small amount of rollover
- Ipsi reflexes elevated in left ear
- Contra reflexes elevated in left ear suggesting retrocochlear pathology
- MRI showed 5 mm acoustic neuroma

# Analysis



- Abnormal reflex responses in left ear indicate 7th nerve affected
- Elevated contralateral thresholds in right ear means that decussating pathways from left VCN to right brainstem affected